

**HERMETIC STRAIGHT MALE RECEPTACLE**  
**SOLDER TYPE - FULL DETENT**

**R222.645.030**

Series : SMP

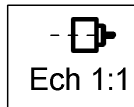
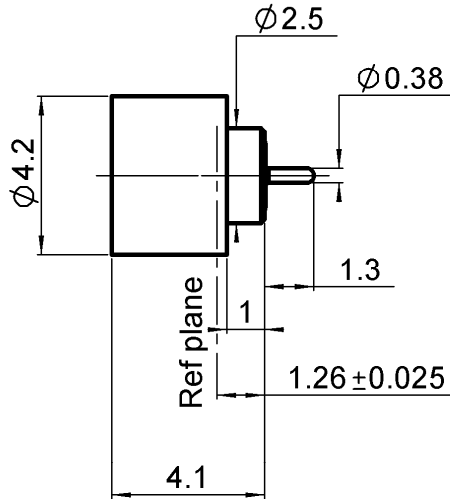

All dimensions are in mm.

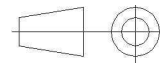

COMPONENTS	MATERIALS	PLATINGS (µm)
BODY	DILVER P1	GOLD 0.5 OVER NICKEL 2
CENTER CONTACT	DILVER P1	GOLD 0.5 OVER NICKEL 2
OUTER CONTACT	-	-
INSULATOR	GLASS	-
GASKET	-	-
OTHERS PARTS	-	-
-	-	-
-	-	-

Issue : 0951 B

In the effort to improve our products, we reserve the right to make changes judged to be necessary.



**HERMETIC STRAIGHT MALE RECEPTACLE**

**R222.645.030**

**SOLDER TYPE - FULL DETENT**

Series : SMP

**PACKAGING**

**SPECIFICATION**

Standard	Unit	Other
<b>100</b>	<b>'W' option</b>	<b>Contact us</b>

**ELECTRICAL CHARACTERISTICS**

**ENVIRONMENTAL**

Impedance	<b>50</b>	$\Omega$
Frequency	<b>0-18</b>	GHz
VSWR	<b>1.15 + 0,0000</b>	x F(GHz) Maxi
Insertion loss	<b>0.12</b>	$\sqrt{F}$ (GHz) dB Maxi
RF leakage	- (	- F(GHz)) dB Maxi
Voltage rating	<b>335</b>	Veff Maxi
Dielectric withstanding voltage	<b>500</b>	Veff mini
Insulation resistance	<b>5000</b>	M $\Omega$ mini

Operating temperature	<b>-65/+165</b>	$^{\circ}$ C
Hermetic seal	<b>10-8</b>	Atm.cm <sup>3</sup> /s
Panel leakage		

**OTHERS CHARACTERISTICS**

Assembly instruction

Others :

**MECHANICAL CHARACTERISTICS**

Center contact retention		
Axial force – Mating end	<b>6.8</b>	N mini
Axial force – Opposite end	<b>6.8</b>	N mini
Torque		N.cm mini
Recommended torque		
Mating		N.cm
Panel nut		N.cm
Mating life	<b>100</b>	Cycles mini
Weight	<b>0,1650</b>	g

Issue : 0951 B

In the effort to improve our products, we reserve the right to make changes judged to be necessary.



**HERMETIC STRAIGHT MALE RECEPTACLE**

**R222.645.030**

**SOLDER TYPE - FULL DETENT**

Series : SMP

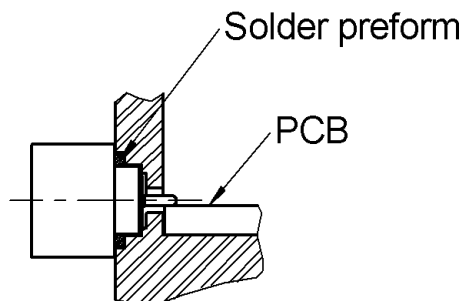

1. Degrease and clean connector and box
2. Solder the connector on the panel  
we advise SnAg4 Cu0.5, we recommend a low residue flux.  
Preheating at 100 °C. Take care not to exceed 260°C during solder operation
3. Solder the pin on the track  
we advise SnAg4 Cu0.5, we recommend a low residue flux.  
Preheating at 100 °C (only for ceramic substrate). Take care not to exceed 260°C during solder operation

Panel mounting hole

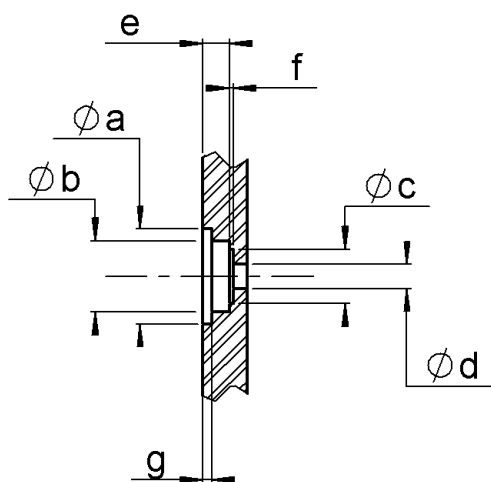

a	3,43 - 3,47
b	2,59 - 2,61
c	1,95 - 2,05
d	0,87 - 0,91
e	0,94 - 0,99
f	0,13 - 0,17
g	0,28 - 0,38

Issue : 0951 B

In the effort to improve our products, we reserve the right to make changes judged to be necessary.

